



HIGH TECHNICAL LEVEL
OF THE SOLUTION



PROJECT AND TECHNICAL
SUPPORT



WE WILL COME
AND EXPLAIN IT ALL



SPECIALIZED TECHNICAL
TRAINING



SALES, INSTALLATION, REPAIRS,
REVISIONS, MODERNIZATION
AND CONSULTING



ATYPICAL MANUFACTURING CRANES AND HANDLING EQUIPMENT

EVERYTHING FOR SAFE LOAD HANDLING

2023

DESIGN | IMPLEMENTATION | DOCUMENTATION | RECONSTRUCTION AND SERVICE LIFE EXTENSION | SERVICE | REVISION | TRAINING

Double-girder crane with working load capacity of 10,000 kg, a span of 26 m and a hydraulic clamshell grab.



Wheeled traverser with a working load limit of 70,000 kg and length of 36 m.



Automatic manipulator for straw bales.



CONTENTS



ATYPICAL MANUFACTURING CRANES



CRANE HOISTS AND TROLLEYS



MANIPULATORS AND POSITIONERS



TECHNOLOGICAL AND RAIL MOVING PLATFORMS



PNEUMATIC, ELECTRIC AND HYDRAULIC PLATFORMS



HEAVY LOAD TROLLEYS



Dear customers,

NOPO ENGINEERING s.r.o. became a part of the Carl Stahl Group in 2021. We are one of the most important production engineering companies operating in the field of special lifting, handling and transport technology on the Czech and Slovak markets. Our products are designed to meet customer specifications with regard to the optimal production process, reliable operation, and fast service. We thus create individual solutions for various technological tasks. We have a high-quality technical expertise in the development of equipment in the form of a highly equipped design team as well as in-house production, assembly and service capacities. This allows us to offer, manufacture and put into operation non-serial equipment, which combine the company's technical capabilities and the customer's needs to deliver an optimal match between the utility value of the solution and the price. You will find we offer comprehensive services. And that's why we are everywhere where something big needs to be moved.

ACCESSORIES



SERVICES



Gantry cranes of higher load groups and atypical technical parameters.

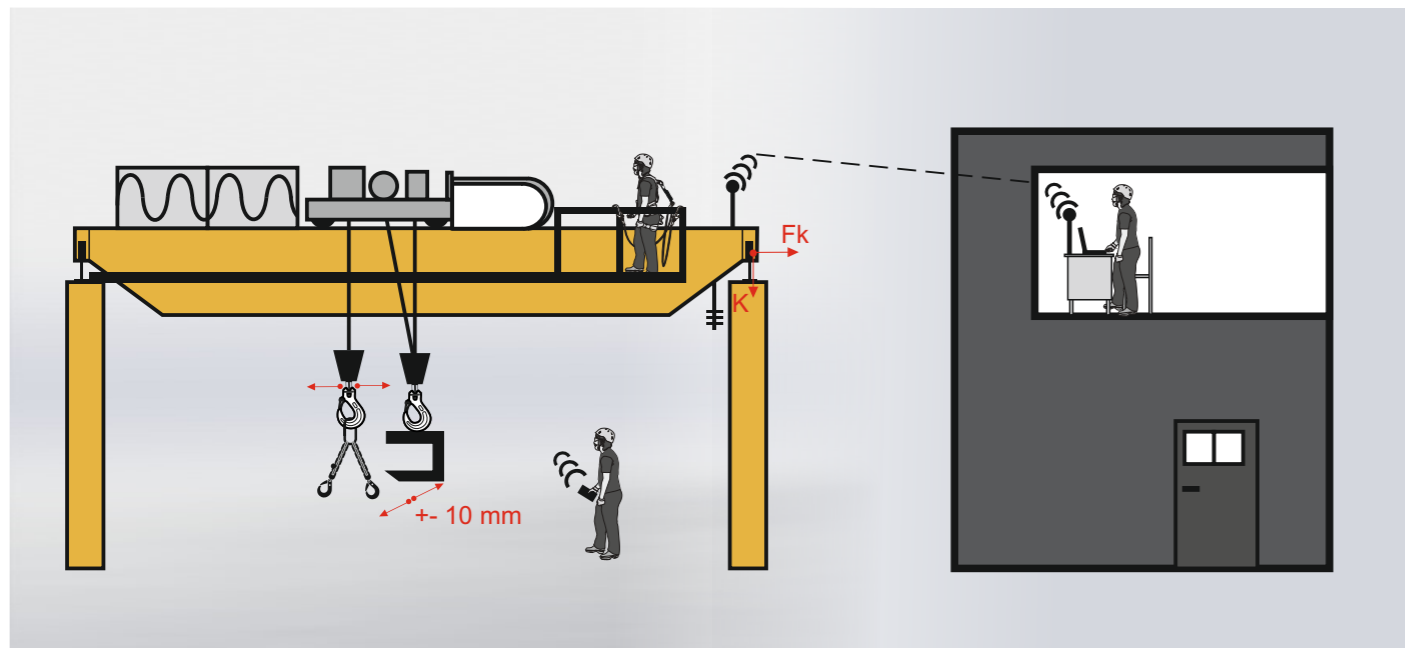

We are engineers, designers, structural engineers, expert consultants, service and revision technicians. We deliver new solutions tailored to the specific operating needs, and we also restore and modernise older crane technology.

ATYPICAL MANUFACTURING CRANES

Each crane is designed for a different use in different conditions. It has its specific equipment, construction dimensions and lifting height. However, load group is an essential parameter of bridge cranes. We specialise in cranes in higher load groups. We have extensive experience across industry, including specific operations in foundries, the automotive, chemical, food industries, and applications in explosive environments. Design, production, installation, management, service, revision, preventive maintenance and repairs, restoration and modernisation - we provide a comprehensive solution.



See our website for more about cranes, our references and services:
www.carlstahl-zvedacitechnika.cz

RESTORATION AND MODERNISATION

We conduct a special assessment to determine the ability to restore retired cranes and crane tracks. We perform reconstruction and modernisation of all parts of cranes according to specific requirements and often with the aim of increasing the load group. By restoring crane equipment and automating it, we increase the efficiency and safety of operations, extending the service life, while also adding specific sensors to crane systems. We expand crane systems to access hard-to-reach places and spaces with structural engineering deficiencies.



PROFESSIONAL TECHNICAL DESIGN ASSISTANCE

We will help you create specific and detailed design specifications and advise you on the technical details. We will help you create tender documentation to ensure all offers in the tender process meet your requirements down to the smallest detail. You will receive an offer from us with professionally developed technical parameters. You can expect high-level design solutions that meet economic and safety criteria.

ECONOMICS OF OPERATION

We ensure that there is no swinging of the load and thus unnecessary time delays during handling. We allow the operator to control the crane from the control room using cameras, eliminating the need for another loading worker. We design the structure of the components according to the customs established by the customer to avoid introducing unnecessary complications, for example during maintenance. According to our own methodology, we extend the service life of crane systems where the crane tracks have exceeded their service life. We operate with a proprietary set of measures to ensure the crane itself exerts the least loading on the tracks as possible. We measure, we conduct material testing. We carefully and expertly calculate the fatigue values of steel structures to facilitate a safe extension of the life of the system by many years. We automate.

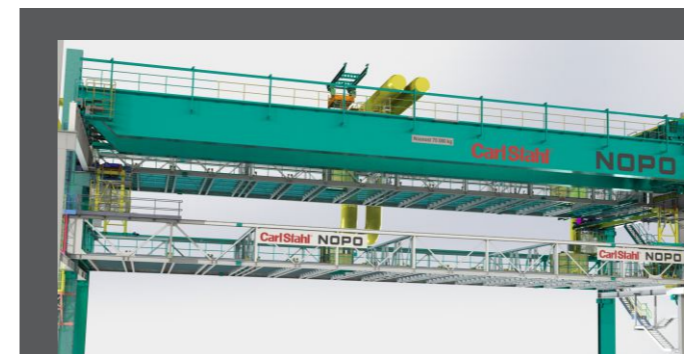

SERVICE, REVISION, RESTORATION

We provide comprehensive maintenance services, from repairs of defects, to preventative maintenance, inspections and revision, on to restoration and reconstruction, automation and service life extension.

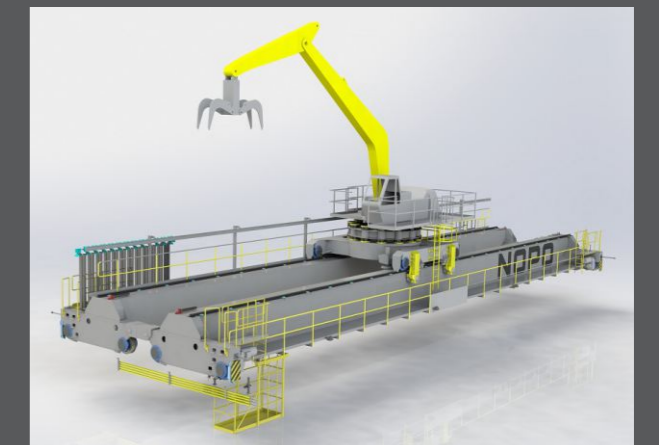

◀ Comprehensive solution of a 70 t / 42 m crane and a two-floor warehouse in a hall.

Production, reconstruction, modernisation.

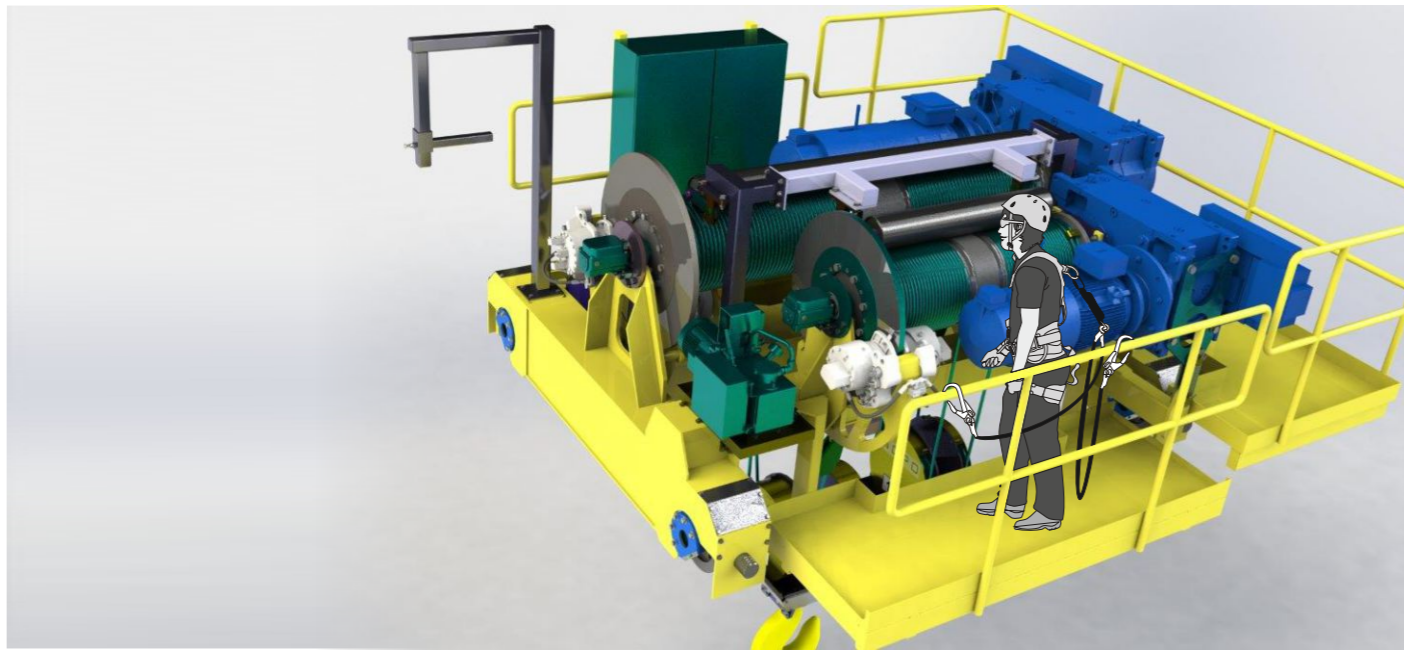

We use hoists of our own design for crane applications in higher load groups. We guarantee an extended service life. We custom tailor hoists to the size to match operating needs and the design parameters.

ATYPICAL CONSTRUCTION

We have extensive experience across industry, including specific operations in foundries, the automotive, chemical, food industries, and applications in explosive environments. We specialise in the construction of hoists for higher load groups, atypical parameters and in the production of high-tonnage hoists for specific operations. Each crane trolley and each hoist we design is unique and is designed and constructed for a specific environment and use. Our hoists are custom tailored to the lifting height, type and speed of travel, and loading group of the given application.

RESTORATION AND MODERNISATION

We routinely modernise crane crab drive systems for the full spectrum of cranes and manipulators. We conduct special assessments for the reconstruction and modernisation of hoists produced by other manufacturers. The first phase in the hoist or crab reconstruction process is a special assessment, which produces a qualified verdict as to if the equipment can even be reconstructed. Our in-house team of engineers conducts this special assessment. We modernise crane crabs and hoists using our in-house team of engineers and designers for the specific environment and planned use.



See our website for more about crane hoists, crane trolleys and our references:
www.carlstahl-zvedacitechnika.cz

PROFESSIONAL TECHNICAL DESIGN ASSISTANCE

We will help you create specific and detailed design specifications and advise you on the technical details. We will help you create tender documentation to ensure all offers in the tender process meet your requirements down to the smallest detail. You will receive an offer from us with professionally developed technical parameters. You can expect high-level design solutions that meet economic and safety criteria.

EKONOMIKA PROVOZU

We design crane hoists so that the load stabilises immediately upon arrival when lifting and moving heavy loads quickly and stops with an accuracy of a few millimetres. We produce crane crabs that can be controlled from a cab or control room using a camera and sensor system and we complement them with additional accessories to increase the efficiency and safety of operation. We design the structure of the components according to the customs established by the customer to avoid introducing unnecessary complications, for example during maintenance. We extend the service life of crane systems when the crab and crane are at the end of their service life.

SERVICE, REVISION, RESTORATION

We provide comprehensive maintenance services, from repairs of defects, to preventative maintenance, inspections and revision, on to restoration and reconstruction, automation and service life extension.

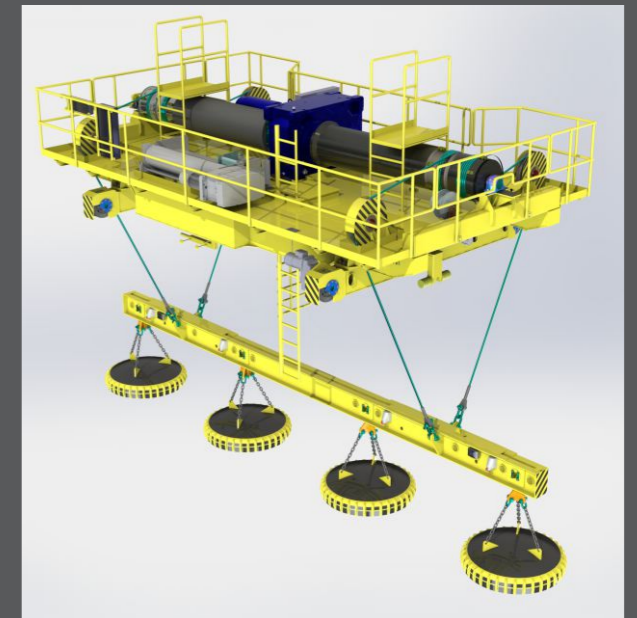

Double drum crab with traverse.

Four-line crab with grab.

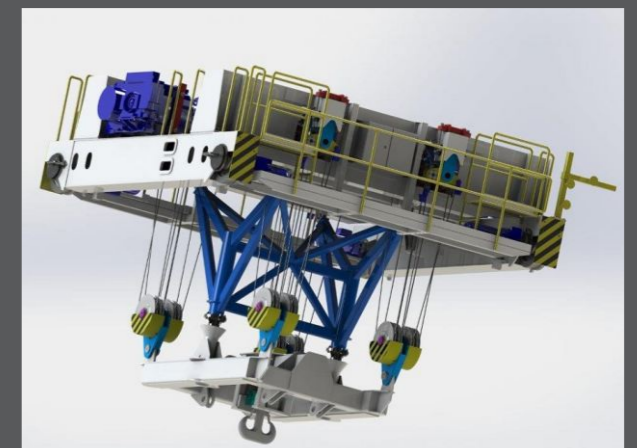
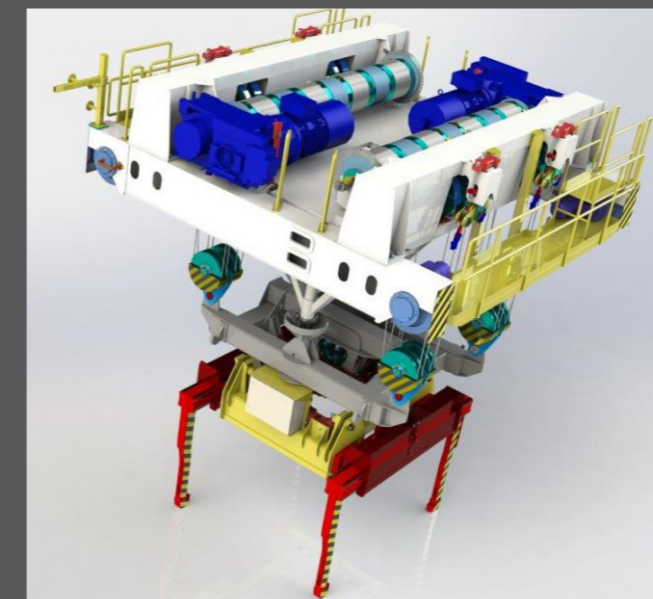

Crane and positioning manipulators, automatic warehouses.

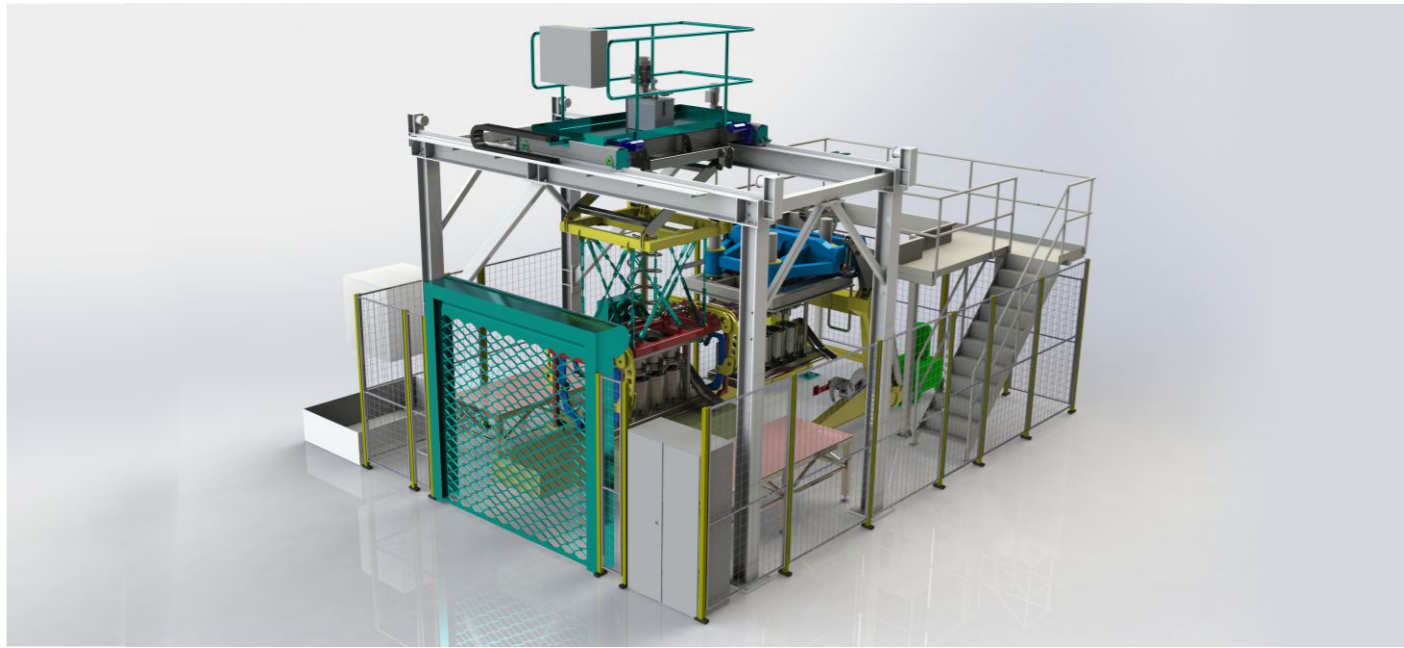

We design and manufacture crane manipulators for non-stop operations and fully automated operations, automatic suspended storage and positioning manipulators to ensure technological operations.

CRANE MANIPULATORS

Crane manipulators are designed on the basis of crane equipment. They are intended for handling loads over large areas, but compared to classic cranes, they are equipped with technology for fully automated operations, load stabilisation systems, specific grippers and sophisticated control technology.

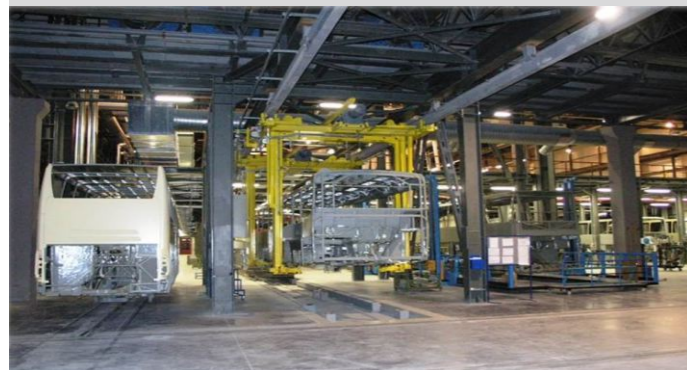

POSITIONING MANIPULATORS

Many companies use a static manipulator of our own design to grasp, lift, rotate and position loads, especially in the automotive industry and for rolling stock applications. Another field in which our positioning manipulators are often used is the production of large metal weldments, for example containers, where continuous rotation and other manipulation must occur during production.



See our website for more about manipulators and our references:
www.carlstahl-zvedacitechnika.cz

PROFESSIONAL TECHNICAL DESIGN ASSISTANCE

At no charge we will help you craft the precise specifications of a solution and advise you on technical details. We will help you create tender documentation to ensure all offers in the tender process meet your requirements down to the smallest detail. You will receive an offer from us with professionally developed technical parameters. You can expect high-level design solutions that meet economic and safety criteria.

AUTOMATIC SUSPENDED STORAGE

To increase the efficiency of crane manipulator operation, the system may be expanded to include suspended automatic storage located directly above production areas and into which production equipment and aids are stored. The manipulator ensures removal and placement in the suspended storage space and picks and stages new equipment and aids.



SERVICE, REVISION, RESTORATION

We provide comprehensive maintenance services, from repairs of defects, to preventative maintenance, inspections and revision, on to restoration and reconstruction, automation and service life extension.



Four-rope manipulator for transporting carts.

Telescopic manipulator with rotation and forks.



Traversers for rolling stock and production processes.



Fully enclosed rail moving platform with a retractable enclosure, working load limit of 135,000 kg and length of 32 m used to move railway units. Remote controlled.

We design and produce traversers for rolling stock for both indoor and outdoor environments. From a detailed offer through implementation to service, revision, certification and modernisation.

MOVING PLATFORMS FOR RAILWAY UNITS

Moving platforms for rolling stock should "sit on the ground" to ensure the working surface has as little height as possible. Moving platforms may be equipped with a whole range of sensors to detect overloading conditions and for automatic and precise stopping. System components include devices for loading and unloading, or systems for full automation.



TECHNOLOGICAL MOVING PLATFORMS

Technological moving platforms facilitate the transverse and longitudinal movement of heavy loads in the production process. We design the lifting (or lowering) and moving speeds, the speed of the rack or door, etc. based on the design capacity. Technological, safety and process requirements are balanced with financial aspects.



See our website for more about moving platforms and our references: www.carlstahl-zvedacitechnika.cz

PROFESSIONAL TECHNICAL DESIGN ASSISTANCE

At no charge we will help you craft the precise specifications of a solution and advise you on technical details. We will help you create tender documentation to ensure all offers in the tender process meet your requirements down to the smallest detail. You will receive an offer from us with professionally developed technical parameters. You can expect high-level design solutions that meet economic and safety criteria.

MOVING PLATFORM AUTOMATION

Automatic machines, semi-automatic machines, automatic safety functions, automatic movement, handling and positioning. Nearly every project has at least one of these attributes. Through automation, we save our customers production time, and thus it is possible to calculate the return on investment very quickly. We have implemented dozens of robotic moving platforms as parts of automated production lines, as well as many simple "smart moving floors".



SERVICE, REVISION, RESTORATION

We provide comprehensive maintenance services, from repairs of defects, to preventative maintenance, inspections and revision, on to restoration and reconstruction, automation and service life extension.



Recessed rail moving platform with working load limit of 135,000 kg and a length of 24 m for the transport of railway units. Semi-automatic controls from the cab.

Above-grade fully enclosed rail moving platform with working load limit of 80,000 kg and a length of 30 m with wedge ramps for the transport of railway units.



Recessed, partially enclosed rail moving platform with working load limit of 120,000 kg and length of 21 m for the transport of railway units. Semi-automatic controls from the cab.



Hydraulic, electric and pneumatic platforms.

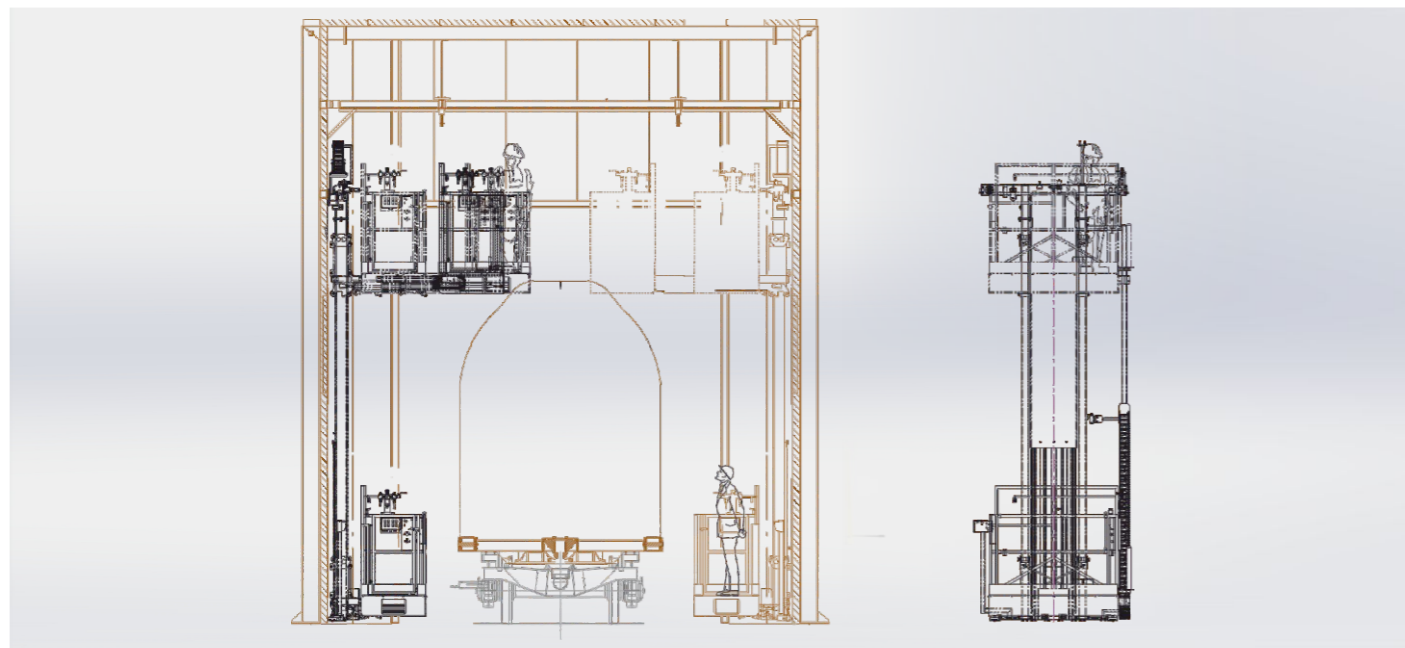

We design and manufacture mobile and stationary technological platforms, especially for preparatory work and painting booths for rolling stock. We also manufacture platforms for dusty, chemical and explosive environments. and modernisation.

TYPES OF TECHNOLOGICAL PLATFORMS

We manufacture technological platforms for surface finish work on wagons and bodies in the following types:

Mobile pneumatic: Designed specifically for explosive environments. In the event of a power failure, the air tanks allow the platform to be lowered.

Mobile electric: Designed for high dust environments in prep booths for sanding and sealing work.

Stationary hydraulic platforms covering the entire booth: Designed for explosive and dusty environments.

SAFETY ELEMENTS

We cover the entire implementation process, including safety devices for personnel both on the platform and off the platform on the roof of the wagon. We design custom booths meeting the safety requirements for the given workspace per the customer's safety requirements, safety standards, and the specific aspects of the process. We also install safety elements to prevent collisions between the technological platform and the wagon.



PROFESSIONAL TECHNICAL DESIGN ASSISTANCE

At no charge we will help you craft the precise specifications of a solution and advise you technical matters. We will help you create tender documentation to ensure all offers in the tender process meet your requirements down to the smallest detail. You will receive an offer from us with professionally developed technical parameters. You can expect high-level design solutions that meet economic and safety criteria.

CONTROLS AND ACCESSORIES

Controls are handled using buttons or pedals. Platforms are equipped with holders for tools for painting, additional lighting and folding gangways to access the wagon. Tracks, wheels and support rollers are also part of the delivery. We also fit out painting booths with conveyors and traversers for longitudinal and transverse movement, manipulators, positioners or lifts.



SERVICE, REVISION, RESTORATION

We provide comprehensive maintenance services, from repairs of defects, to preventative maintenance, inspections and revision, on to restoration and reconstruction, automation and service life extension.



▲ Electric platform with hoist.

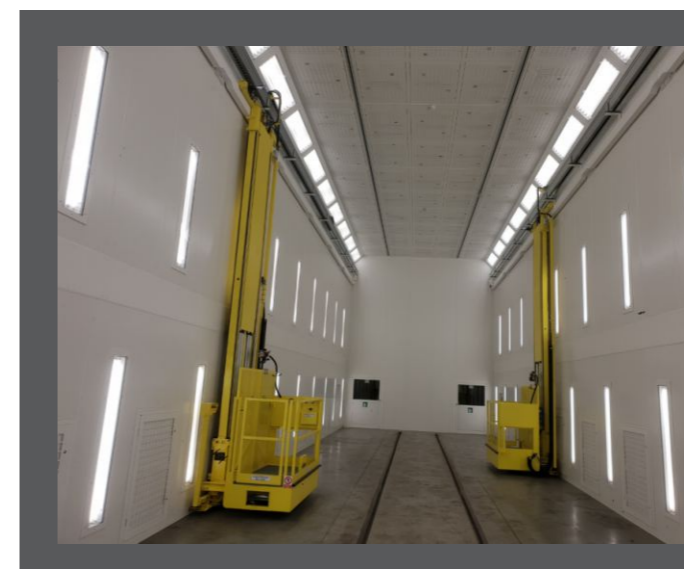

◀ Pneumatic platform.



See our website for more about platforms and our references:
www.carlstahl-zvedacitechnika.cz

HEAVY LOAD TROLLEYS

Electric powered, battery powered and manual trolleys.

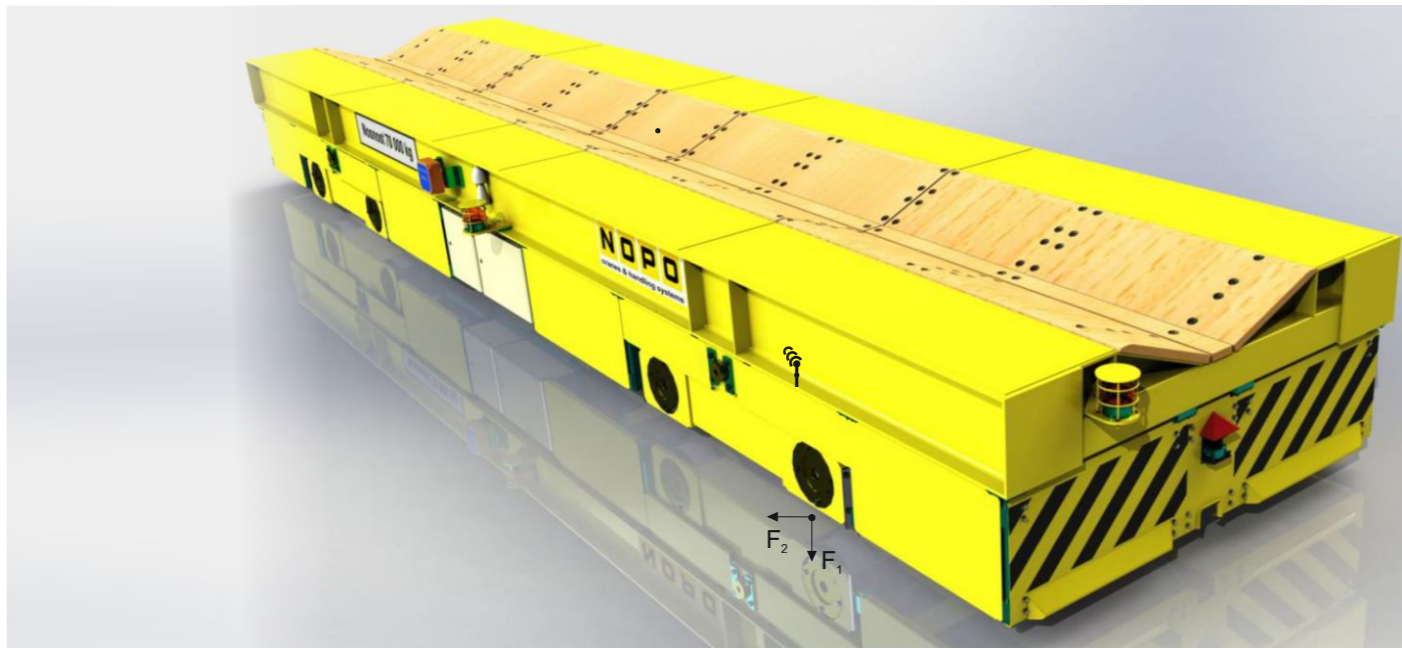

We design and manufacture trolleys and mobile platforms for carrying heavy loads customised to your specific operating needs. We often choose to manufacture solutions that operate on rails to significantly reduce resistance.

MOST COMMON TYPES OF TROLLEYS

Trolleys for rotating container parts, rail trolleys for handling coils, mobile rail trolleys for form replacement, rail trolleys for carrying plate and sheet materials and battery-powered rail trolleys. If handling with the load on the trolley is required, we manufacture rail trolleys with electric rotation and adjustable arms, tipping trolleys, lifting rail trolleys for coils, mobile platforms, non-motorised platform trolleys and rail trolleys for panels with a lift.



TRAVERSER SOLUTIONS

We manufacture trolleys in three main groups based on their power source:

- Electric powered (tethered) trolleys
- Battery powered trolleys
- Manually operated trolleys

A trolley is always a combination of a chassis, drive assembly and special superstructure designed per the customer's specific needs.



PROFESSIONAL TECHNICAL DESIGN ASSISTANCE

At no charge we will help you craft the precise specifications of a solution and advise you on technical details. We will help you create tender documentation to ensure all offers in the tender process meet your requirements down to the smallest detail. You will receive an offer from us with professionally developed technical parameters. You can expect high-level design solutions that meet economic and safety criteria.



▲ Trolley with positioning device for rail unit bogie wheels.



▲ Traverser on tires with special enclosure.

SERVICE, REVISION, RESTORATION

We provide comprehensive maintenance services, from repairs of defects, to preventative maintenance, inspections and revision, on to restoration and reconstruction, automation and service life extension.



Coil trolley. ▼



See our website for more about transfer trolleys and our references:
www.carlstahl-zvedacitechnika.cz

We offer a broad range of accessories for crane equipment.



We deliver accessories for our cranes and crane equipment from competing brands. Get accessories from us customised to the specific needs of a new project, and when modernising and restoring legacy equipment.

PROFESSIONAL ASSISTANCE WHEN SELECTING ACCESSORIES

To maximise equipment efficiency, we recommend selecting the ideal accessories during the crane design process. We can help you choose the right spare parts or alternative products. You will receive an offer from us with professionally developed technical parameters. You can expect high-level and efficient solutions that meet economic and safety criteria.

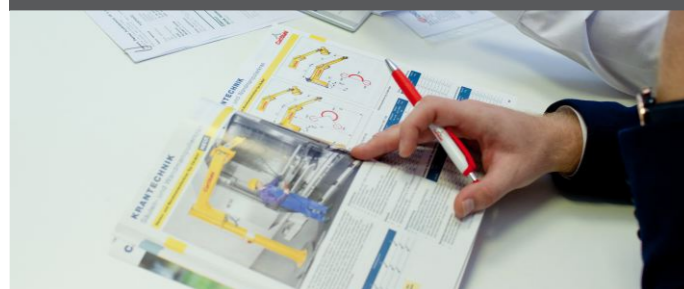

See our website for more about accessories:
www.carlstahl-zvedacitechnika.cz

MECHANICAL ACCESSORIES

Grapples, traverses, suspended manipulators. Accessories for connecting to an existing crane or its hook. We equip cranes with manipulators for automatic grasping of the load, clamshell grabs and orange peel (polyp) grapples, or traverses, either magnetic or technological. For a new solution, the choice of accessories is based on the design and capacity calculation validation and calculations with regard to the efficiency of the device as a whole. We supply accessories that are subject to rapid wear, ropes and other equipment both for cranes and manipulators we manufacture and for competitors' crane systems.

Overview of additional lifting equipment products and accessories offered by Carl Stahl.



SOFTWARE

SKEW PREVENTION SYSTEM

This system prevents the skewing of crane wheels on the crane track. As the crab moves towards one end of the crane track, loading shifts more towards one end of the crane. The crane then has the tendency not to track properly and to skew. The system ensures power is reduced to the less loaded side of the crane to prevent tracking problems. The crane must be equipped with a variable frequency drive in this case.

DRIVE-TO-POSITION SYSTEM

This system for semi-automatic crane operation allows the crane operator to use a remote control to set "delivery" coordinates after attaching and lifting the load into the transport position, to which the crane then automatically moves the load. The system automatically selects a track and speed. This is often combined with the oscillation prevention system. Positioning accuracy with this combination can be within 10 mm.

SWAY PREVENTION SYSTEM

This system prevents load sway during transport by the crane. Passive systems predict load sway based on changes in crane trolley travel speed to eliminate it, while active systems employ a camera installed on the crane trolley together with a chequerboard placed on the beam, automatic manipulator or traverse. The system actively eliminates sway by subtly moving the crane or braking its speed in a certain direction.

REMOTE CRANE MANAGEMENT

We equip cranes with online diagnostics, which we augment with online consulting when restarting a crane. The moment a malfunction occurs, we can connect to the crane system online and perform diagnostics of the malfunction and past operation.

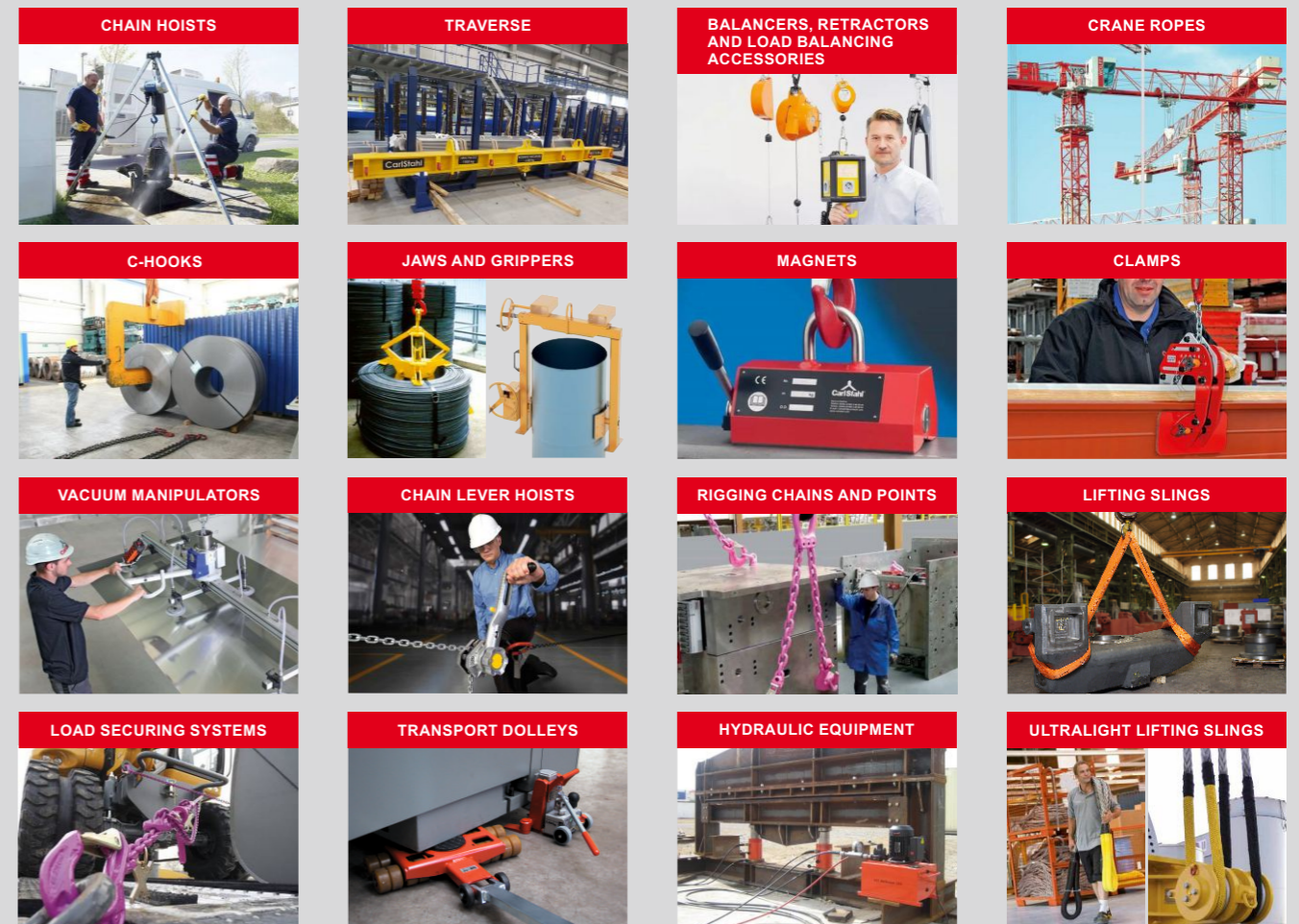

Comprehensive customer service.



We have provided exclusive service for decades from consulting, to manufacturing, service, and revision. Refurbishment of end-of-life cranes with a special assessment is a commonly used service. All with the help of in-house teams.

SERVICE, INSPECTIONS AND REVISION

We have our own service team specialised in repair, inspection and revision of our cranes and cranes from other manufacturers. For crane ropes, crane track and rigging equipment, we carry out the necessary diagnostics by stereoscopic, photogrammetric, magnetic and mechanical defectoscopy.



RECONSTRUCTION OF CRANES AND THEIR PARTS

According to the specific requirements of customers, our engineering team will prepare a special assessment of lifting equipment. This is the basis for making a decision on the means and scope of reconstruction and modernisation of affected crane parts, from steel structures and track, to hoists, drive components, and the electrical installation. Reconstruction improves the efficiency and safety of equipment operations, extending their service life, while adding functionalities, including specific sensors, extending access into hard-to-reach places or improving solutions in spaces with structural engineering deficiencies.

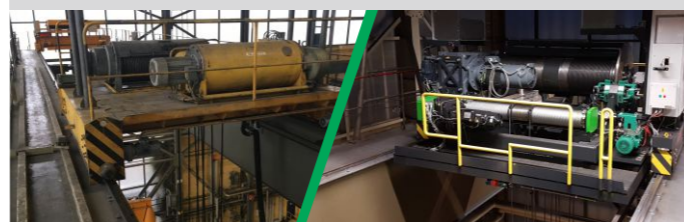

**NONSTOP CRANE SERVICE:
CALL 800 802 801**



See our website for more about maintenance services: www.carlstahl-zvedacitechnika.cz

PROFESSIONAL TECHNICAL DESIGN ASSISTANCE

We will help you create specific and detailed design specifications and advise you on the technical details. We will help you create tender documentation to ensure all offers in the tender process meet your requirements down to the smallest detail. You will receive an offer from us with professionally developed technical parameters. You can expect high-level design solutions that meet economic and safety criteria.

EMERGENCY RESPONSE STRATEGY

An emergency response strategy, for which we were recognised by Volkswagen as the best group supplier, consists of redundancy in critical crane system parts. Should a device malfunction, the customer is able to work around it in a few simple steps and continue to operate the equipment. When remote equipment management is installed, our operations centre conducts online diagnostics once a malfunction occurs and they recommend a procedure for how to proceed (e.g. connecting backup equipment located directly on the crane). This emergency response strategy allows us to immediately remedy most malfunctions without requiring technicians to make a service call or an equipment shutdown. Redundancy in certain devices does not significantly affect the price of the solution and is very popular with our customers.

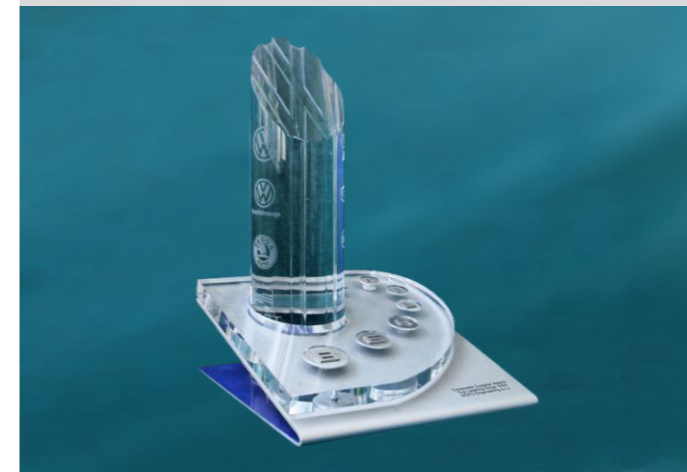

**SERVICE AND REVISION:
LIFTING EQUIPMENT, HYDRAULICS,
RIGGING EQUIPMENT, PROTECTIVE
EQUIPMENT
CALL +420 604 816 280**

FALL PROTECTION FOR PERSONNEL

We deliver comprehensive fall protection systems, including structural engineering calculations, revision services, and training.



LABELLING AND RECORDS

We use Integrated Services web application, we provide customers with an overview of the status of all lifting equipment and accessories, including data on the operation of the equipment and operational documentation, management of warranties and various deadlines for regular maintenance and revisions. We process information about equipment operation, monitor operating and load data and keep complete records.





HIGH TECHNICAL LEVEL OF THE SOLUTION



PROJECT AND TECHNICAL SUPPORT



WE WILL COME AND EXPLAIN IT ALL



SPECIALIZED TECHNICAL TRAINING



SALES, INSTALLATION, REPAIRS, REVISIONS, MODERNIZATION AND CONSULTING



Carl Stahl & spol, s.r.o.
Mikulovická 4, 190 17 Prague
Company ID: 62418394
Business hours: Mon-Fr 8:00 AM to 4:30 PM
Phone: +420 281 920 100
Email: info@carlstahl.cz
Web: www.carlstahl.cz

Branch:
NOPO Engineering s.r.o.
Zemědělská 989/3, 500 03 Hradec Králové
Phone: +420 730 895 989
Email: nopo@nopo.cz

www.carlstahl-zvedacitechnika.cz



WHAT ELSE CAN WE HELP YOU WITH?



JEŘÁBOVÁ TECHNIKA
VŠE PRO BEZPEČNOU MANIPULACI S BŘEMENY
2022

NÁVRH | REALIZACE | DOKUMENTACE | REVIZE | ŠKOLENÍ

CRANE EQUIPMENT



ZDVIHACÍ TECHNIKA
VŠE PRO BEZPEČNOU MANIPULACI S BŘEMENY
2022

NÁVRH | REALIZACE | DOKUMENTACE | REVIZE | ŠKOLENÍ

LIFTING EQUIPMENT



HI-FORCE
PRŮMYSLOVÁ VYSOKOTLAKÁ HYDRAULICKÁ ZAŘÍZENÍ
2022

KOMPATIBILNÍ SE VŠEMI ZAŘÍZENÍMI S PRACOVNÍM TLAKEM 700 BAR

NÁVRH | REALIZACE | SERVIS A OPRAVY | PRONÁJEM | ŠKOLENÍ

HYDRAULICS



JISTĚNÍ OSOB
SYSTÉMY A VYBAVENÍ PRO PRÁCI VE VÝŠKÁCH A NAD VOLNOU HLOUBKOU
2022

- PORADENSTVÍ
- NÁVRH ŘEŠENÍ NA MÍRU
- STATICKÉ POSOUZENÍ KOTEVNÍCH MÍST
- DODÁVKA, MONTÁŽ A UVEDENÍ DO PROVOZU
- DOKUMENTACE, REVIZE
- ZAŠKOLENÍ NA UŽÍVÁNÍ JISTÍCÍCH PROSTŘEDKŮ
- ŠKOLENÍ PRO PRÁCI VE VÝŠKÁCH S OSVĚDČENÍM

NÁVRH | REALIZACE | DOKUMENTACE | REVIZE | ŠKOLENÍ

PROTECTION OF PERSONNEL